

Alarm Switchboard Module, Type 1 (ASM-1) Topology

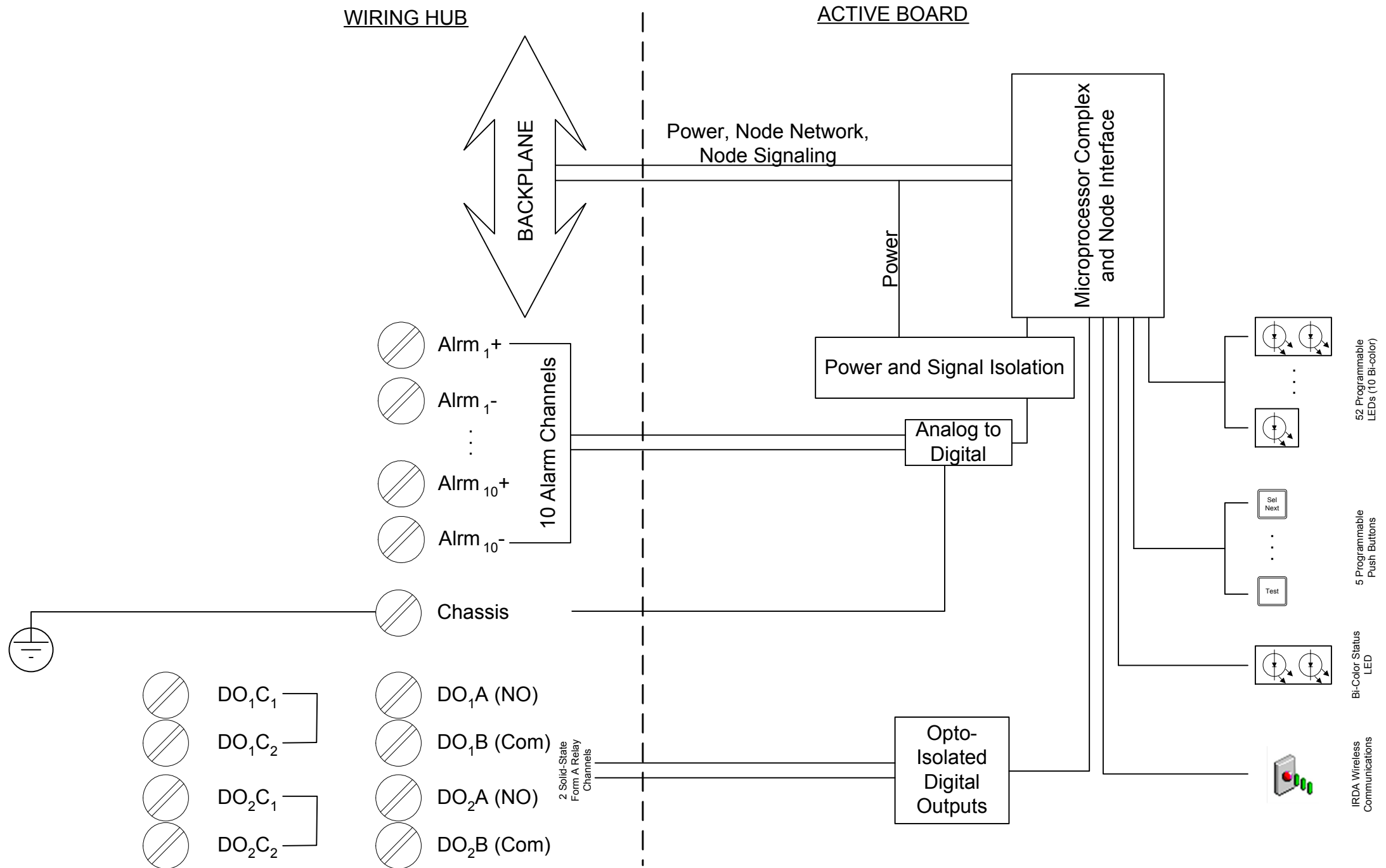

Alarm Switchboard Module, Type 1 (ASM-1) Alarm Input

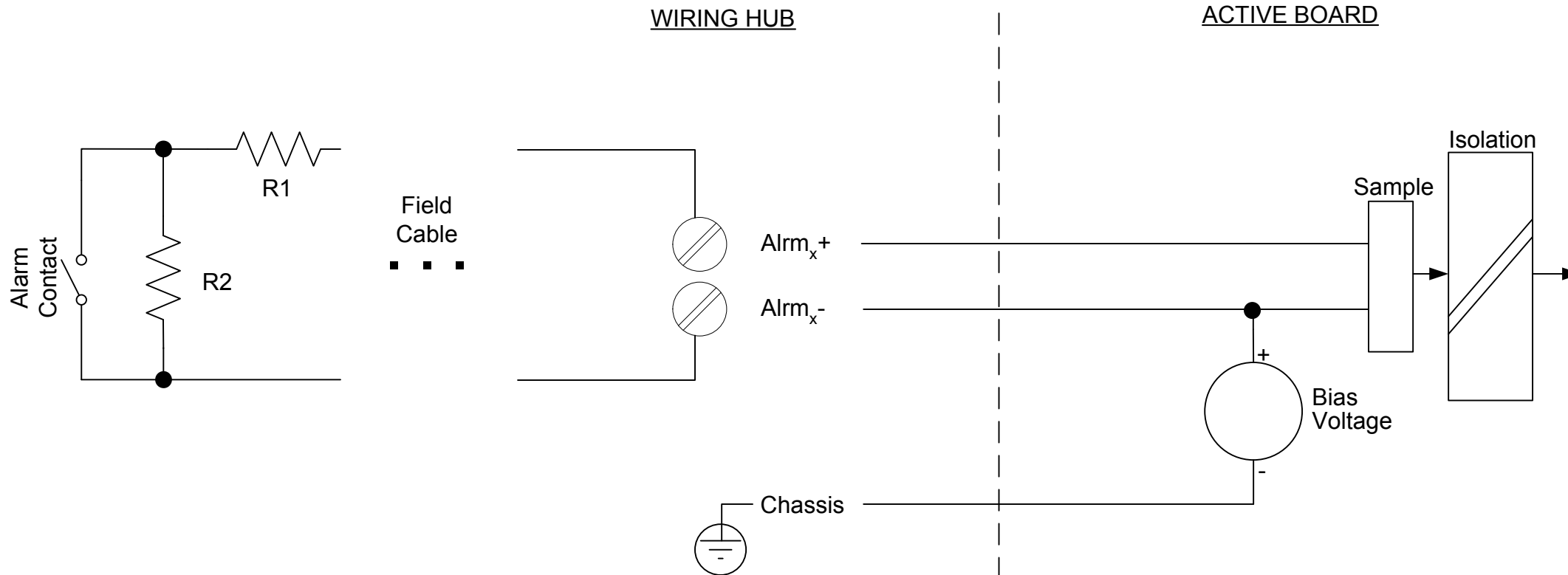

Notes:

- R1 and R2 should be installed as close as possible to the alarm contact.
- Allowable values for R1 are 0 to 11.7k ohms. Minimum value to allow short circuit detection is the Maximum Cable Resistance + 300 ohms. The typical value is 1.5k ohms.
- R2 can be omitted from the circuit. If removed then the cable open detection feature will be disabled. If used, allowable values for R2 are 300 to 12k ohms. The typical value is 6.8k ohms.
- In addition to above, the relationship between R1 and R2 must meet the following:
 - a) Allowable values for $R1 + R2$ are from 300 to 12k ohms
 - b) $R2 > [1.1 * (R1 + 300 + \text{Maximum Cable Resistance})]$
- Maximum Cable Resistance = Maximum Alrm+ Wire Resistance plus Maximum Alrm- Wire Resistance.

Alarm Switchboard Module, Type 1 (ASM-1) AC Digital Output

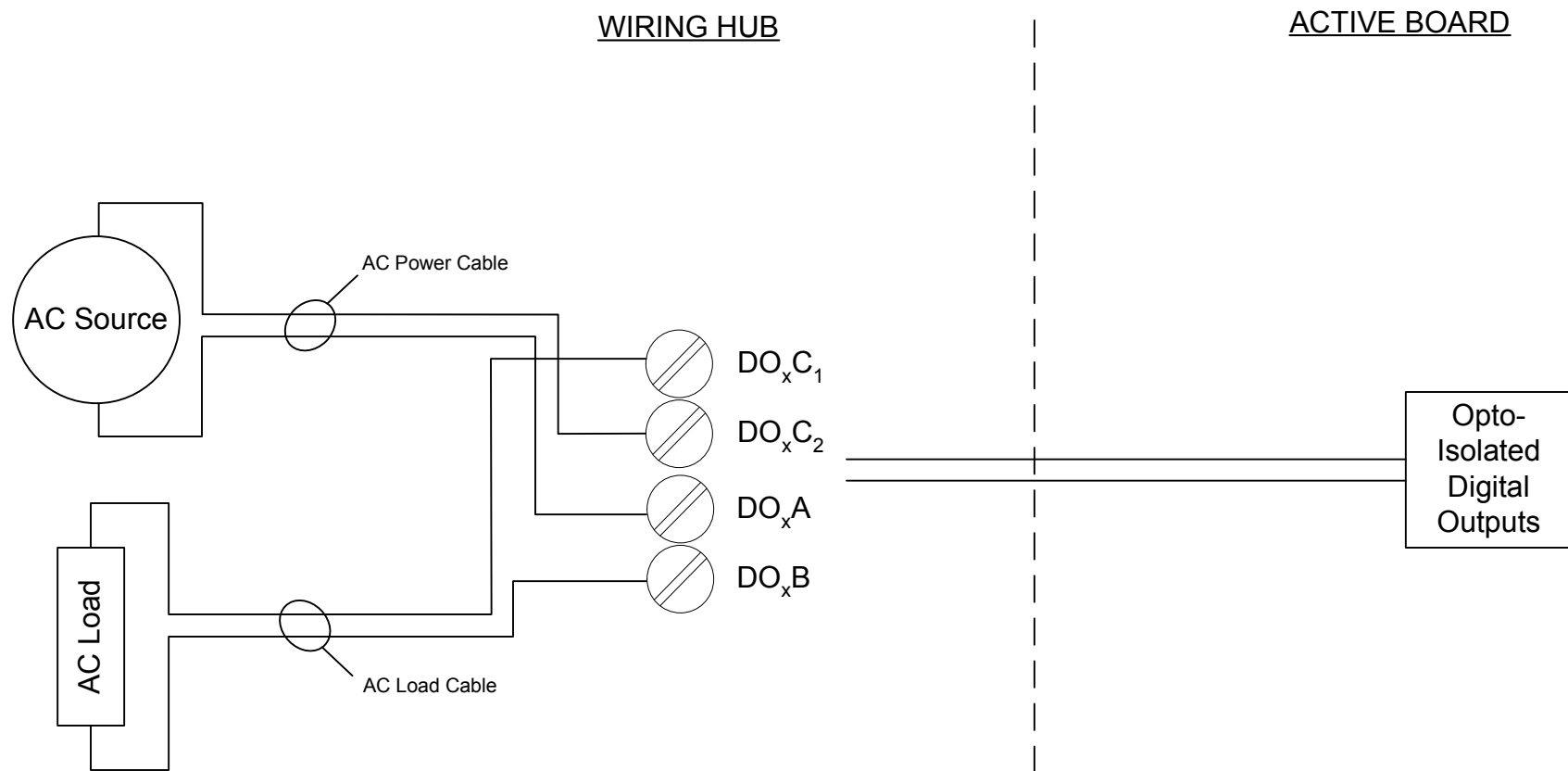

Note:

DO_xC₁ is connected to DO_xC₂ through traces on the wiring hub PC board.

Alarm Switchboard Module, Type 1 (ASM-1) Parallel AC Digital Output Across Multiple ASM-1 Modules

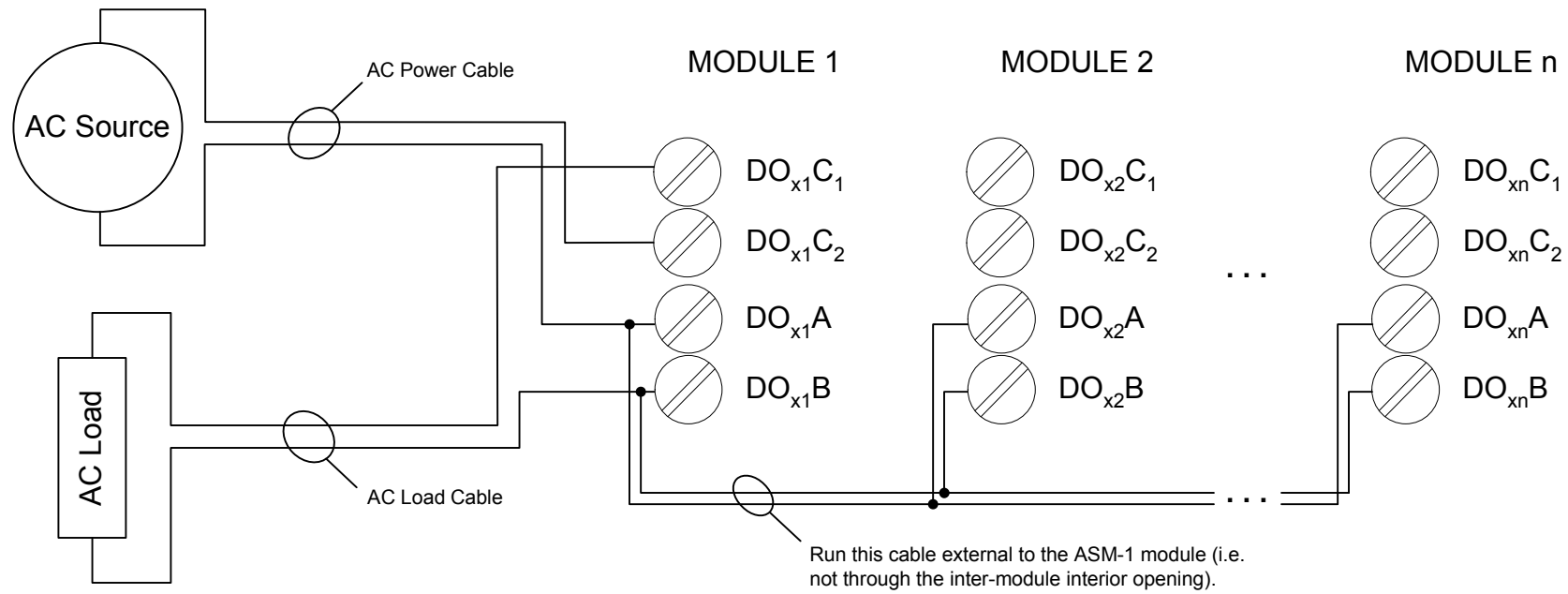



ALARM SWITCHBOARD
MODULE ASM-1

SELECT

CH1

CH2

CH3

CH4

CH5

CH6

CH7

CH8

CH9

CH10

NORMAL CUTOUT
 STNDBY

NORMAL CUTOUT
 STNDBY

NORMAL CUTOUT
 STNDBY

NORMAL CUTOUT
 STNDBY

NORMAL CUTOUT
 STNDBY

NORMAL CUTOUT
 STNDBY

NORMAL CUTOUT
 STNDBY

NORMAL CUTOUT
 STNDBY

NORMAL CUTOUT
 STNDBY

NORMAL CUTOUT
 STNDBY

GND
FAULT
POS
NEG

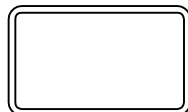
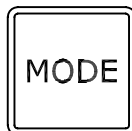

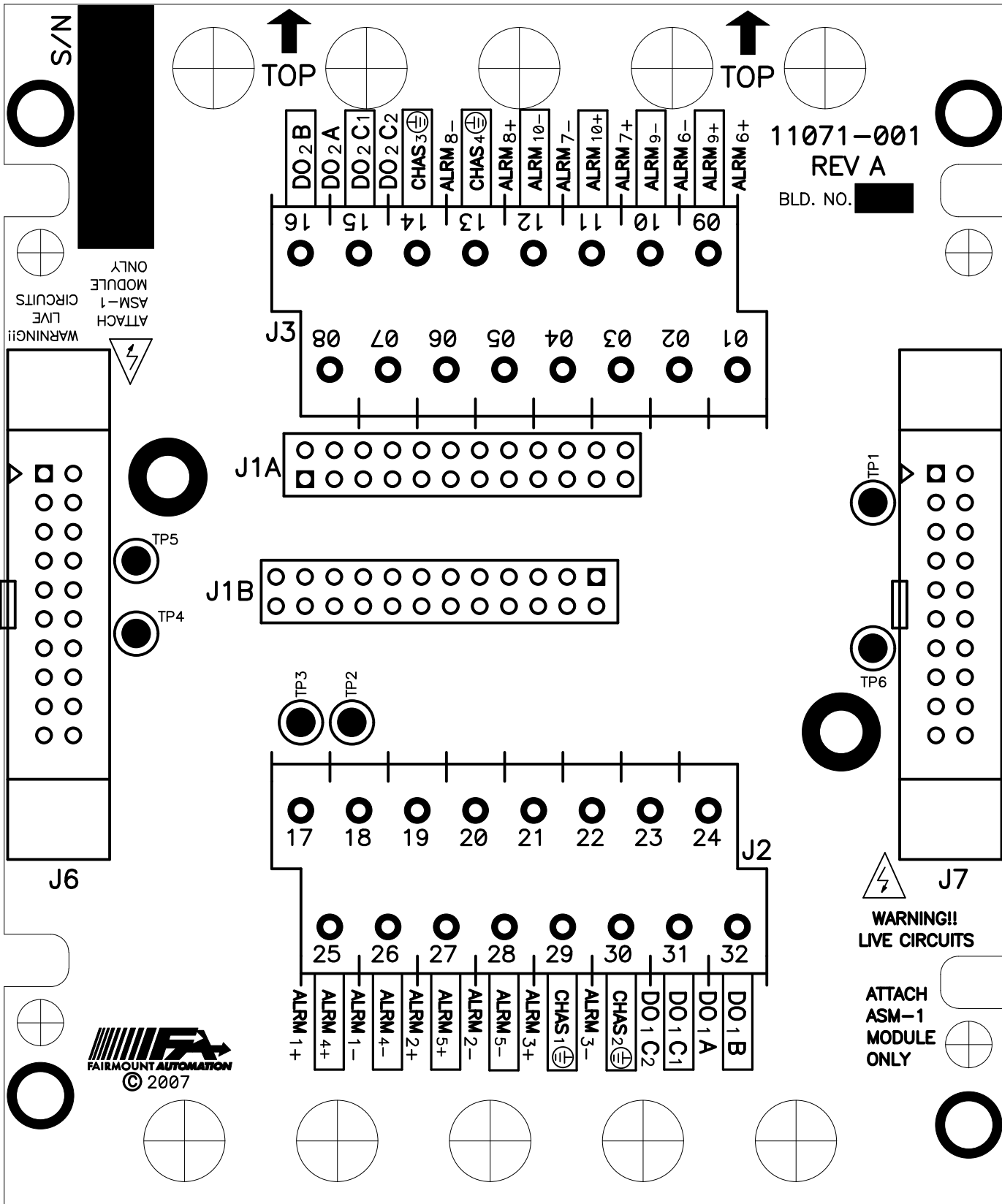

S/N

TOP

TOP

11071-001
REV A

BLD. NO. [REDACTED]

WARNING!!
ATTACH
LIVE
CIRCUITS
ASM-1
MODULE
ONLY



J3

J1A

J1B

TP3

TP2

TP5

TP4

TP1

TP6

17

18

19

20

21

22

23

24

J2

25

26

27

28

29

30

31

32

ALRM 1+

ALRM 4+

ALRM 1-

ALRM 4-

ALRM 2+

ALRM 5+

ALRM 2-

ALRM 5-

ALRM 3+

ALRM 6+

CHAS 1

ALRM 3-

CHAS 2

DO 1 C2

DO 1 C1

DO 1 A

DO 1 B

J6

J7

WARNING!!
LIVE CIRCUITS

ATTACH
ASM-1
MODULE
ONLY

